



# Quick Guide VLT<sup>®</sup> Micro Drive FC 51





## Contents

<b>1 Quick Guide</b>	<b>2</b>
1.1 Safety	2
1.1.1 Safety Instructions	3
1.2 Introduction	3
1.2.1 Available Literature	3
1.2.2 IT Line Power	3
1.2.3 Avoid Unintended Start	4
1.3 Installation	4
1.3.2 Side-by-Side Installation	4
1.3.3 Mechanical Dimensions	5
1.3.4 Connecting to Line Power and Motor	7
1.3.5 Control Terminals	7
1.3.6 Power Circuit - Overview	8
1.3.7 Load Sharing/Brake	9
1.4 Programming	9
1.4.1 Programming on Automatic Motor Adaptation (AMA)	9
1.4.2 Programming on Automatic Motor Tuning (AMT)	10
1.5 Parameter Overview	11
1.6 Troubleshooting	15
1.6.1 Warnings and Alarms	15
1.7 Specifications	16
1.8 General Technical Data	18
1.9 Special Conditions	21
1.9.1 Derating for Ambient Temperature	21
1.9.2 Derating for Low Air Pressure	21
1.9.3 Derating for Running at Low Speeds	21
1.10 Options	22
<b>Index</b>	<b>23</b>

# 1 Quick Guide

## 1.1 Safety

### **⚠ WARNING**

#### HIGH VOLTAGE

Adjustable frequency drives contain high voltage when connected to AC line power. Failure to perform installation, start-up, and maintenance by qualified personnel could result in death or serious injury.

- Installation, start-up, and maintenance must be performed by qualified personnel only.

### **⚠ WARNING**

#### UNINTENDED START

When the adjustable frequency drive is connected to AC line power, the motor may start at any time, causing risk of death, serious injury, equipment, or property damage. The motor can be started with an external switch, a serial bus command, an input reference signal from the LCP or LOP, or after a cleared fault condition.

1. Disconnect the adjustable frequency drive from line power whenever personal safety considerations make it necessary to avoid unintended motor start.
2. Press [Off/Reset] on the LCP before programming any parameters.
3. The adjustable frequency drive, motor, and any driven equipment must be in operational readiness when the adjustable frequency drive is connected to AC line power.

### **⚠ WARNING**

#### DISCHARGE TIME

The adjustable frequency drive contains DC link capacitors that can remain charged even when the adjustable frequency drive is not powered. Failure to wait the specified time after power has been removed before performing service or repair work could result in death or serious injury.

1. Stop motor.
2. Disconnect AC line power, permanent magnet type motors, and remote DC link power supplies, including battery backups, UPS, and DC link connections to other adjustable frequency drives.
3. Wait for the capacitors to discharge fully before performing any service or repair work. The duration of waiting time is specified in *Table 1.1*.

Size	Minimum waiting time (min)
M1, M2 and M3	4
M4 and M5	15

Table 1.1 Discharge Time

#### Leakage Current (>3.5 mA)

Follow national and local codes regarding protective grounding of equipment with a leakage current > 3.5 mA. Adjustable frequency drive technology implies high frequency switching at high power. This generates a leakage current in the ground connection. A fault current in the adjustable frequency drive at the output power terminals might contain a DC component that can charge the filter capacitors and cause a transient ground current. The ground leakage current depends on various system configurations including RFI filtering, shielded motor cables, and adjustable frequency drive power.

EN/IEC61800-5-1 (Power Drive System Product Standard) requires special care if the leakage current exceeds 3.5 mA. Grounding must be reinforced in one of the following ways:

- Ground wire of at least 10 mm<sup>2</sup>.
- Two separate ground wires, both complying with the dimensioning rules.

See EN 60364-5-54 § 543.7 for further information.

#### Using RCDs

Where residual current devices (RCDs), also known as ground leakage circuit breakers (GLCBs), are used, comply with the following:

1. Use RCDs of type B only which are capable of detecting AC and DC currents.
2. Use RCDs with an inrush delay to prevent faults due to transient ground currents.
3. Dimension RCDs according to the system configuration and environmental considerations.

#### Motor Thermal Protection

Motor overload protection is possible by setting *parameter 1-90 Motor Thermal Protection* to [4] trip. For the North American market: Implemented function provides class 20 motor overload protection, in accordance with NEC.

#### Installation at High Altitudes

For altitudes above 6,600 ft [2,000 m], contact Danfoss.

### 1.1.1 Safety Instructions

- Make sure the adjustable frequency drive is properly grounded.
- Do not remove AC line input connections, motor connections or other power connections while the adjustable frequency drive is connected to line power.
- Protect users against supply voltage.
- Protect the motor against overloading according to national and local regulations.
- The ground leakage current exceeds 3.5 mA.
- The [Off/Reset] key is not a safety switch. It does not disconnect the adjustable frequency drive from line power.

## 1.2 Introduction

### 1.2.1 Available Literature

#### **NOTICE!**

This Quick Guide contains the basic information necessary for installing and running the adjustable frequency drive.

If more information is needed, the literature listed below can be downloaded from:

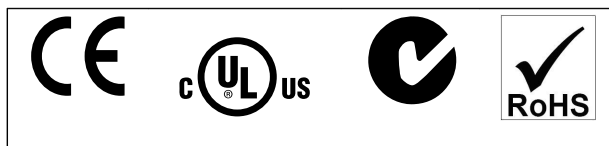

Table 1.2 Approvals

The adjustable frequency drive complies with UL508C thermal memory retention requirements. For more information, refer to the section *Motor Thermal Protection* in the *Design Guide*.

### 1.2.2 IT Line Power

#### **NOTICE!**

##### IT Line Power

Installation on an isolated line power source, i.e., IT line power.

**Max. supply voltage allowed when connected to line power: 440 V.**

As an option, Danfoss offers recommended line filters for improved harmonics performance.

### 1.2.3 Avoid Unintended Start

While the adjustable frequency drive is connected to line power, the motor can be started/stopped using digital commands, bus commands, references or via the LCP or LOP.

- Disconnect the adjustable frequency drive from line power whenever personal safety considerations make it necessary to avoid unintended start of any motors.
- To avoid unintended start, always press [Off/Reset] before changing parameters.



Equipment containing electrical components may not be disposed of together with domestic waste.

It must be separately collected with electrical and electronic waste according to local and currently valid legislation.

## 1.3 Installation

### 1.3.1 Before Commencing Repair Work

1. Disconnect the FC 51 from line power (and external DC supply if present.)
2. Wait for 4 min (M1, M2 and M3) and 15 min (M4 and M5) for discharge of the DC link. See *Table 1.1*.
3. Disconnect DC bus terminals and brake terminals (if present).
4. Remove motor cable.

### 1.3.2 Side-by-Side Installation

The adjustable frequency drive can be mounted side-by-side for IP20 rating units and requires 4 in [100 mm] clearance above and below for cooling. Refer to *chapter 1.7 Specifications* for details on environmental ratings of the adjustable frequency drive.

### 1.3.3 Mechanical Dimensions

A template for drilling can be found on the flap of the packaging.

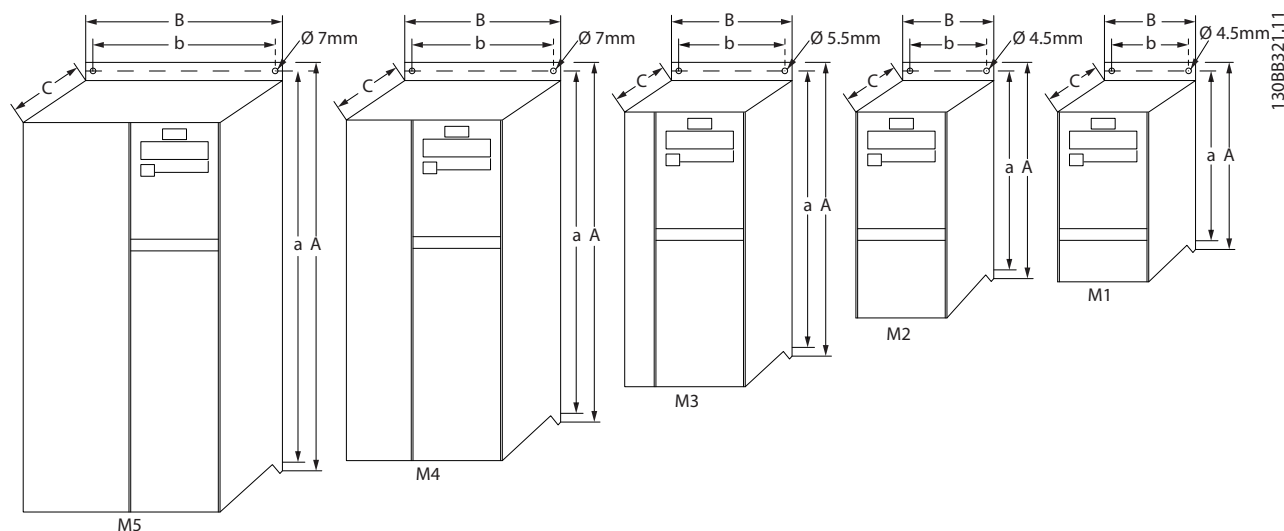

	Power [kW]			Height [mm]			Width [mm]		Depth <sup>1)</sup> [mm]	Max. Weight [kg]
	1x200–240 V	3x200–240 V	3x380–480 V	A	A (incl. decoupling plate)	a	B	b		
M1	0.18–0.75	0.25–0.75	0.37–0.75	150	205	140.4	70	55	148	1.1
M2	1.5	1.5	1.5–2.2	176	230	166.4	75	59	168	1.6
M3	2.2	2.2–3.7	3.0–7.5	239	294	226	90	69	194	3.0
M4			11.0–15.0	292	347.5	272.4	125	97	241	6.0
M5			18.5–22.0	335	387.5	315	165	140	248	9.5

<sup>1)</sup> For LCP with potentiometer, add 1/3 inch (7.6 mm).

Figure 1.1 Mechanical Dimensions

#### **NOTICE!**

All cabling must comply with national and local regulations on cable cross-sections and ambient temperature. Copper conductors required, (140°–167°F [60°–75°C]) recommended.

Enclosure	Power [kW]			Torque [Nm]					
	1x200–240 V	3x200–240 V	3x380–480 V	Line	Motor	DC connection/Brake	Control Terminals	Ground	Relay
M1	0.18–0.75	0.25–0.75	0.37–0.75	1.4	0.7	Spade <sup>1)</sup>	0.15	3	0.5
M2	1.5	1.5	1.5–2.2	1.4	0.7	Spade <sup>1)</sup>	0.15	3	0.5
M3	2.2	2.2–3.7	3.0–7.5	1.4	0.7	Spade <sup>1)</sup>	0.15	3	0.5
M4			11.0–15.0	1.3	1.3	1.3	0.15	3	0.5
M5			18.5–22.0	1.3	1.3	1.3	0.15	3	0.5

<sup>1)</sup> Spade connectors (6.3 mm Faston plugs)

Table 1.3 Tightening of Terminals

### Branch circuit protection

To protect the installation against electrical and fire hazard, all branch circuits in an installation, switch gear, machines, etc., must be short-circuited and overcurrent-protected according to national/international regulations.

### Short circuit protection

Danfoss recommends using the fuses mentioned in the following tables to protect service personnel or other equipment in case of an internal failure in the unit or short-circuit on DC link. The adjustable frequency drive provides full short-circuit protection in case of a short-circuit on the motor or brake output.

### Overcurrent protection

Provide overload protection to avoid overheating of the cables in the installation. Overcurrent protection must always be carried out according to national regulations.

### Non-UL compliance

If UL/cUL is not to be complied with, Danfoss recommends using the fuses mentioned in *Table 1.4*, which ensures compliance with EN50178/IEC61800-5-1:

In case of malfunction, not following the fuse recommendation may result in damage to the adjustable frequency drive and the installation.

	Max. Fuses UL						Max. fuses non-UL
	Bussmann	Bussmann	Bussmann	Littelfuse	Ferraz-Shawmut	Ferraz-Shawmut	
<b>1X200–240 V</b>							
kW	Type RK1	Type J	Type T	Type RK1	Type CC	Type RK1	Type gG
0K18-0K37	KTN-R15	JKS-15	JJN-15	KLN-R15	ATM-R15	A2K-15R	16A
0K75	KTN-R25	JKS-25	JJN-25	KLN-R25	ATM-R25	A2K-25R	25A
1K5	KTN-R35	JKS-35	JJN-35	KLN-R35	-	A2K-35R	35A
2K2	KTN-R50	JKS-50	JJN-50	KLN-R50	-	A2K-50R	50A
<b>3x200–240 V</b>							
0K25	KTN-R10	JKS-10	JJN-10	KLN-R10	ATM-R10	A2K-10R	10A
0K37	KTN-R15	JKS-15	JJN-15	KLN-R15	ATM-R15	A2K-15R	16A
0K75	KTN-R20	JKS-20	JJN-20	KLN-R20	ATM-R20	A2K-20R	20A
1K5	KTN-R25	JKS-25	JJN-25	KLN-R25	ATM-R25	A2K-25R	25A
2K2	KTN-R40	JKS-40	JJN-40	KLN-R40	ATM-R40	A2K-40R	40A
3K7	KTN-R40	JKS-40	JJN-40	KLN-R40	-	A2K-40R	40A
<b>3x380–480 V</b>							
0K37–0K75	KTS-R10	JKS-10	JJS-10	KLS-R10	ATM-R10	A6K-10R	10A
1K5	KTS-R15	JKS-15	JJS-15	KLS-R15	ATM-R15	A2K-15R	16A
2K2	KTS-R20	JKS-20	JJS-20	KLS-R20	ATM-R20	A6K-20R	20A
3K0	KTS-R40	JKS-40	JJS-40	KLS-R40	ATM-R40	A6K-40R	40A
4K0	KTS-R40	JKS-40	JJS-40	KLS-R40	ATM-R40	A6K-40R	40A
5K5	KTS-R40	JKS-40	JJS-40	KLS-R40	-	A6K-40R	40A
7K5	KTS-R40	JKS-40	JJS-40	KLS-R40	-	A6K-40R	40A
11K0	KTS-R60	JKS-60	JJS-60	KLS-R60	-	A6K-60R	63A
15K0	KTS-R60	JKS-60	JJS-60	KLS-R60	-	A6K-60R	63A
18K5	KTS-R60	JKS-60	JJS-60	KLS-R60	-	A6K-60R	80A
22K0	KTS-R60	JKS-60	JJS-60	KLS-R60	-	A6K-60R	80A

Table 1.4 Fuses



### 1.3.4 Connecting to Line Power and Motor

The adjustable frequency drive is designed to operate all standard 3-phased asynchronous motors. The adjustable frequency drive is designed to accept line power/motor cables with a maximum cross-section of 4 mm<sup>2</sup>/10 AWG (M1, M2 and M3) and maximum cross-section 16 mm<sup>2</sup>/6 AWG (M4 and M5).

- Use a shielded/armored motor cable to comply with EMC emission specifications, and connect this cable to both the decoupling plate and the motor metal.
  - Keep motor cable as short as possible to reduce the noise level and leakage currents.
  - For further details on mounting of the decoupling plate, see *VLT Micro FC 51 Decoupling Mounting Plate Instructions*.
  - Also see EMC-compatible Installation in the *Design Guide*.
1. Mount the ground wires to PE terminal.
  2. Connect the motor to terminals U, V and W.
  3. Mount line power supply to terminals L1/L, L2 and L3/N (3-phase) or L1/L and L3/N (single-phase) and tighten.

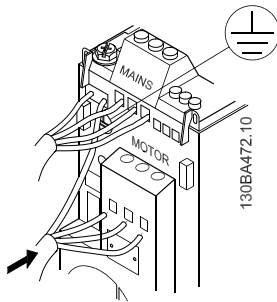

Figure 1.2 Mounting of Ground Cable, Line Power and Motor Wires

### 1.3.5 Control Terminals

All control cable terminals are located underneath the terminal cover in front of the adjustable frequency drive. Remove the terminal cover using a screwdriver.

### NOTICE!

See back of terminal cover for outlines of control terminals and switches.

Do not operate switches with power on the adjustable frequency drive.

6-19 Terminal 53 Mode must be set according to Switch 4 position.

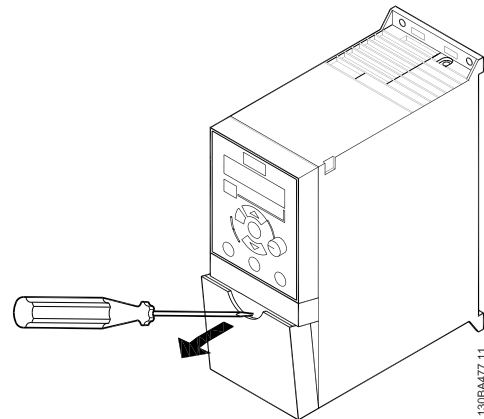

Figure 1.3 Removing Terminal Cover

Switch 1	*Off=PNP terminals 29 On=NPN terminals 29
Switch 2	*Off=PNP terminal 18, 19, 27 and 33 On=NPN terminal 18, 19, 27 and 33
Switch 3	No function
Switch 4	*Off=Terminal 53 0-10 V On=Terminal 53 0/4-20 mA
*=default setting	

Table 1.5 Settings for S200 Switches 1-4

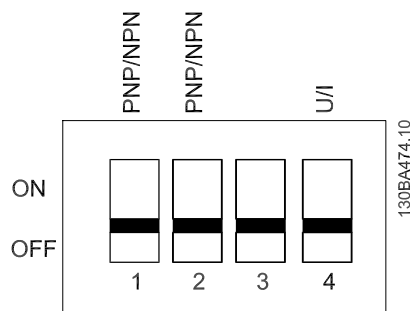

Figure 1.4 S200 Switches 1-4

Figure 1.5 shows all control terminals of the adjustable frequency drive. Applying Start (terminal 18) and an analog reference (terminal 53 or 60) make the adjustable frequency drive run.

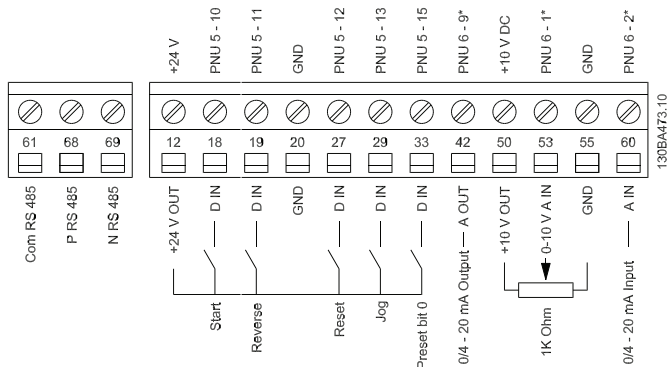

Figure 1.5 Overview of Control Terminals in PNP configuration and Factory Settings

### 1.3.6 Power Circuit - Overview

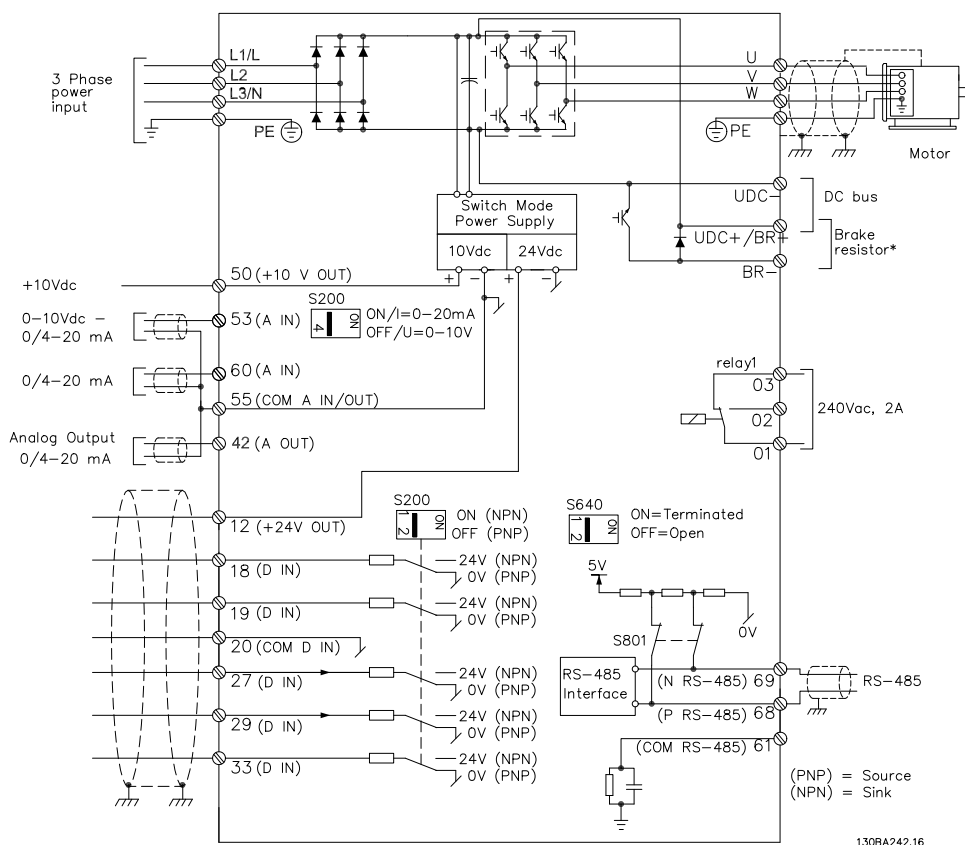

Figure 1.6 Diagram Showing all Electrical Terminals

\* Brake (BR+ and BR-) are not applicable for M1.

Brake resistors are available from Danfoss. Improved power factor and EMC performance can be achieved by installing optional Danfoss line filters. Danfoss power filters can also be used for load sharing.

### 1.3.7 Load Sharing/Brake

Use 6.3 mm insulated Faston plugs designed for high voltage for DC (load sharing and brake).

#### Load sharing

Connect terminals -UDC and +UDC/+BR.

#### Brake

Connect terminals -BR and +UDC/+BR (Not applicable for M1).

#### **NOTICE!**

Voltage levels of up to 850 V DC may occur between terminals +UDC/+BR and -UDC. Not short circuit-protected.

## 1.4 Programming

### 1.4.1 Programming on Automatic Motor Adaptation (AMA)

For detailed information on programming, see *VLT Micro Drive FC 51 Programming Guide*.

#### **NOTICE!**

The adjustable frequency drive can also be programmed from a PC via RS-485 COM port by installing the MCT 10 Set-up Software.

This software can either be ordered using code number 130B1000 or downloaded from the Danfoss website: [www.danfoss.com/BusinessAreas/DrivesSolutions/software-download](http://www.danfoss.com/BusinessAreas/DrivesSolutions/software-download)

Press [Menu] to select one of the following menus:

#### Status

For readouts only.

#### Quick Menu

For access to Quick Menus 1 and 2, respectively.

#### Main Menu

For access to all parameters.

#### Navigation Keys

[Back]: For moving to the previous step or layer in the navigation structure.

[▲] [▼]: For navigating between parameter groups, parameters and within parameters.

[OK]: For selecting a parameter and for accepting changes to parameter settings.

Pressing [OK] for more than 1 s enters *Adjust* mode. In *Adjust* mode, it is possible to make fast adjustment by pressing [▲] [▼] combined with [OK].

Press [▲] [▼] to change value. Press [OK] to shift between digits quickly.

To exit *Adjust* mode, press [OK] more than 1 s again with changes saved or press [Back] without changes saved.

#### Operation Keys

A yellow light above the operation keys indicates the active key.

[Hand]: Starts the motor and enables control of the adjustable frequency drive via the LCP.

[Off/Reset]: The motor stops except when in alarm mode, in that case, the motor is reset.

[Auto]: The adjustable frequency drive is controlled either via control terminals or serial communication.

[Potentiometer]: The potentiometer works in two ways depending on the mode in which the adjustable frequency drive is running.

In *Auto Mode*, the potentiometer acts as an extra programmable analog input.

In *Hand Mode*, the potentiometer controls local reference.

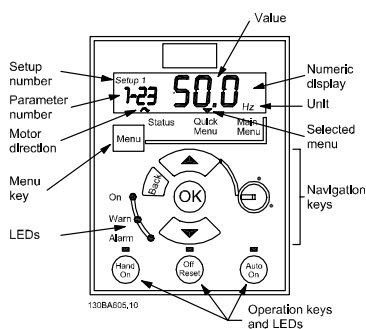

Figure 1.7 Description of LCP Keys and Display

## 1.4.2 Programming on Automatic Motor Tuning (AMT)

It is highly recommended to run AMT because it measures the electrical characteristics of the motor to optimize compatibility between the adjustable frequency drive and the motor under VVC<sup>plus</sup> mode.

- The adjustable frequency drive builds a mathematical model of the motor for regulating output motor current thus enhancing motor performance.
- Run this procedure on a cold motor for best results. To run AMT, use the numeric LCP (NLCP). There are two AMT modes for adjustable frequency drives.

### Mode 1

1. Enter the main menu.
2. Go to parameter group *1-\*\* Load and Motor*.
3. Press [OK]
4. Set motor parameters using nameplate data for parameter group *1-2\* Motor Data*.
5. Go to *1-29 Automatic Motor Tuning (AMT)*.
6. Press [OK].
7. Select *[2] Enable AMT*
8. Press [OK].
9. The test runs automatically and indicates when it is complete.

### Mode 2

1. Enter the main menu.
2. Go to parameter group *1-\*\* Load and Motor*.
3. Press [OK].
4. Set motor parameters using nameplate data for parameter group *1-2\* Motor Data*.
5. Go to *1-29 Automatic Motor Tuning (AMT)*.
6. Press [OK]
7. Select *[3] Complete AMT with Rotating motor*
8. Press [OK]
9. The test will run automatically and indicate when it is complete.

### **NOTICE!**

In mode 2, the rotor rotates during the AMT progress.  
No load should be added on motor in this AMT progress.

### 1.5 Parameter Overview

Parameter Overview			
<p><b>0-** Operation/Display</b>  <b>0-0* Basic Settings</b>  <b>0-03 Regional Settings</b>  <b>0-04 Oper. State at Power-up (Hand)</b>            [0] Resume            *[1] Forced stop, ref=old            [2] Forced stop, ref=0  <b>0-1* Set-up Handling</b>  <b>0-10 Active Set-up</b>            *[1] Set-up 1            [2] Set-up 2            [9] Multi Set-up  <b>0-11 Edit Set-up</b>            *[1] Set-up 1            [2] Set-up 2            [9] Active Set-up  <b>0-12 Link Set-ups</b>            [0] Not Linked            *[20] Linked  <b>0-31 Custom Readout Min Scale</b>            0.00–9,999.00 * 0.00  <b>0-32 Custom Readout Max Scale</b>            0.00–9999.00 * 100.0  <b>0-4* LCP</b>  <b>0-40 [ ] Key on LCP</b>            [0] Disabled            *[1] Enabled  <b>0-41 [Off / Reset] Key on LCP</b>            [0] Disable All            *[1] Enable All            [2] Enable Reset Only  <b>0-42 [ ] Key on LCP</b>            [0] Disabled            *[1] Enabled  <b>0-5* Copy/Save</b>  <b>0-50 LCP Copy</b>            *[0] No copy            [1] All to LCP            [2] All from LCP            [3] Size indep. from LCP  <b>0-51 Set-up Copy</b>            *[0] No copy            [1] Copy from Set-up 1            [2] Copy from Set-up 2            [9] Copy from Factory Set-up  <b>0-6* Password</b>  <b>0-60 (Main) Menu Password</b>            0–999 * 0  <b>0-61 Access to Main/Quick Menu w/o Password</b>            *[0] Full access            [1] LCP: Read Only            [2] LCP:No Access  <b>1-** Load/Motor</b>  <b>1-0* General Settings</b>  <b>1-00 Configuration Mode</b>            *[0] Speed open-loop            [3] Process  <b>1-01 Motor Control Principle</b>            [0] U/f            *[1]  <b>1-03 Torque Characteristics</b>            *[0] Constant torque            [2]</p>	<p><b>1-05 Local Mode Configuration</b>            [0] Speed Open-loop            *[2] As config in par. 1-00  <b>1-2* Motor Data</b>  <b>1-20 Motor Power [kW] [HP]</b>            [1] 0.09 kW/0.12 HP            [2] 0.12 kW/0.16 HP            [3] 0.18 kW/0.25 HP            [4] 0.25 kW/0.33 HP            [5] 0.37 kW/0.50 HP            [6] 0.55 kW/0.75 HP            [7] 0.75 kW/1.00 HP            [8] 1.10 kW/1.50 HP            [9] 1.50 kW/2.00 HP            [10] 2.20 kW/3.00 HP            [11] 3.00 kW/4.00 HP            [12] 3.70 kW/5.00 HP            [13] 4.00 kW/5.40 HP            [14] 5.50 kW/7.50 HP            [15] 7.50 kW/10.00 HP            [16] 11.00 kW/15.00 HP            [17] 15.00 kW/20.00 HP            [18] 18.50 kW/25.00 HP            [19] 22.00 kW/29.50 HP            [20] 30.00 kW/40.00 HP  <b>1-22 Motor Voltage</b>            50–999 V *230–400 V  <b>1-23 Motor Frequency</b>  <b>1-24 Motor Current</b>            0.01–100.00 A *Motortype dep.  <b>1-25 Motor Nominal Speed</b>            100–9,999 rpm *Motortype dep.  <b>1-29</b>            *[0] Off            [2] Enable            [3] Complete with rotating motor  <b>1-3* Adv. Motor Data</b>  <b>1-30 Stator Resistance (Rs)</b>            [Ohm] * Dep. on motor data  <b>1-33 Stator Leakage Reactance (X1)</b>            [Ohm] * Dep. on motor data  <b>1-35 Main Reactance (Xh)</b>            [Ohm] * Dep. on motor data  <b>1-5* Load Indep. Setting</b>  <b>1-50 Motor Magnetization at 0 Speed</b>            0–300% * 100%  <b>1-52 Min Speed Norm. Magnet. [Hz]</b>            0.0–10.0 Hz * 0.0 Hz  <b>1-55 U/f Characteristic - U</b>            0–999.9 V  <b>1-56 U/f Characteristic - F</b>            0–400 Hz  <b>1-6* Load Depen. Setting</b>  <b>1-60 Low Speed Load Compensation</b>            0–199% * 100%  <b>1-61 High Speed Load Compensation</b>            0–199% * 100%  <b>1-62 Slip Compensation</b>            -400–399% * 100%</p>	<p><b>1-63 Slip Compensation Time Constant</b>            0.05–5.00 s * 0.10 s  <b>1-7* Start Adjustments</b>  <b>1-71</b>            0.0–10.0 s * 0.0 s  <b>1-72 Start Function</b>            [0] DC Hold/delay time            [1] DC brake/delay time            *[2] Coast/delay time  <b>1-73</b>            *[0] Disabled            [1]  <b>1-8* Stop Adjustments</b>  <b>1-80 Function at Stop</b>            *[0] Coast            [1] DC hold  <b>1-82 Min Speed for Funct. at Stop [Hz]</b>            0.0–20.0 Hz * 0.0 Hz  <b>1-9* Motor Temperature</b>  <b>1-90 Motor Thermal Protection</b>            *[0] No protection            [1] Thermistor warning            [2] Thermistor trip            [3] Warning            [4] Trip  <b>1-93 Thermistor Resource</b>            *[0] None            [1] Analog input 53            [6] Digital input 29  <b>2-** Brakes</b>  <b>2-0* DC Brake</b>  <b>2-00 DC Hold Current</b>            0–150% * 50%  <b>2-01 DC Brake Current</b>            0–150% * 50%  <b>2-02 DC Braking Time</b>            0.0–60.0 s * 10.0 s  <b>2-04 DC Brake Cut-in Speed</b>            0.0–400.0 Hz * 0.0 Hz  <b>2-1* Brake Energy Funct.</b>  <b>2-10 Brake Function</b>            *[0] Off            [1] Resistor brake            [2] AC brake  <b>2-11 Brake Resistor (ohm)</b>            Min/Max/default: Power size dep.  <b>2-14 Brake Voltage reduce</b>            0–Power size dep.* 0  <b>2-16 AC Brake, Max current</b>            0–150% * 100%  <b>2-17 Overvoltage Control</b>            *[0] Disabled            [1] Enabled (not at stop)            [2] Enabled  <b>2-2* Mechanical Brake</b>  <b>2-20 Release Brake Current</b>            0.00–100.0 A * 0.00 A  <b>2-22 Activate Brake Speed [Hz]</b>            0.0–400.0 Hz * 0.0 Hz  <b>3-** Reference / Ramps</b>  <b>3-0* Reference Limits</b>  <b>3-00 Reference Range</b>            *[0] Min. - Max.            [1] -Max - +Max</p>	<p><b>3-02 Minimum Reference</b>            -4,999–4,999 * 0.000  <b>3-03 Maximum Reference</b>            -4,999–4,999 * 50.00  <b>3-1* References</b>  <b>3-10 Preset Reference</b>            -100.0–100.0% * 0.00%  <b>3-11 Jog Speed [Hz]</b>            0.0–400.0 Hz * 5.0 Hz  <b>3-12 Catch up/Slow-down Value</b>            0.00–100.0% * 0.00%  <b>3-14 Preset Relative Reference</b>            -100.0–100.0% * 0.00%  <b>3-15 Reference Resource 1</b>            [0] No function            *[1] Analog Input 53            [2] Analog input 60            [8] Pulse input 33            [11] Local bus ref            [21] LCP Potentiometer  <b>3-16 Reference Resource 2</b>            [0] No function            [1] Analog in 53            *[2] Analog in 60            [8] Pulse input 33            *[11] Local bus reference            [21] LCP Potentiometer  <b>3-17 Reference Resource 3</b>            [0] No function            [1] Analog Input 53            [2] Analog input 60            [8] Pulse input 33            *[11] Local bus ref            [21] LCP Potentiometer  <b>3-18 Relative Scaling Ref. Resource</b>            *[0] No function            [1] Analog Input 53            [2] Analog input 60            [8] Pulse input 33            [11] Local bus ref            [21] LCP Potentiometer  <b>3-4*</b>  <b>3-40</b>            *[0] Linear            [2]  <b>3-41</b>            0.05–3600 s * 3.00 s (10.00 s<sup>1)</sup>)  <b>3-42</b>            0.05–3600 s * 3.00 s (10.00 s<sup>1</sup>)  <b>3-5*</b>  <b>3-50</b>            *[0] Linear            [2]  <b>3-51</b>            0.05–3600 s * 3.00 s (10.00 s<sup>1</sup>)  <b>3-52</b>            0.05–3,600 s * 3.00 s (10.00 s<sup>1</sup>)  <b>3-8* Other Ramps</b>  <b>3-80</b>            0.05–3,600 s * 3.00 s (10.00 s<sup>1</sup>)  <b>3-81 Quick Stop Time</b>            0.05–3,600 s * 3.00 s (10.00 s<sup>1</sup>)</p>

<sup>1)</sup> M4 and M5 only

<p><b>4-** Limits/Warnings</b>  <b>4-1* Motor Limits</b>  <b>4-10</b>          *[0] If Par. 1-00 is set to close-loop control          [1]          *[2] Both if Par. 1-00 is set to open-loop control  <b>4-12 Motor Speed Low Limit [Hz]</b>          0.0–400.0 Hz * 0.0 Hz  <b>4-14 Motor Speed High Limit [Hz]</b>          0.1–400.0 Hz * 65.0 Hz  <b>4-16 Torque Limit Motor Mode</b>          0–400% * 150%  <b>4-17 Torque Limit Generator Mode</b>          0–400% * 100%  <b>4-4* Adj. Warnings 2</b>  <b>4-40 Warning Frequency Low</b>          0.00–Value of 4-41 Hz * 0.0 Hz  <b>4-41 Warning Frequency High</b>          Value of 4-40–400.0 Hz * 400.00 Hz  <b>4-5* Adj. Warnings</b>  <b>4-50 Warning Current Low</b>          0.00–100.00 A * 0.00 A  <b>4-51 Warning Current High</b>          0.0–100.00 A * 100.00 A  <b>4-54 Warning Reference Low</b>          –4,999.000–Value of 4-55 * –4,999.000  <b>4-55 Warning Reference High</b>          Value of 4-54 –4,999.000 * 4,999.000  <b>4-56 Warning Feedback Low</b>          –4,999.000–Value of 4-57 * –4,999.000  <b>4-57 Warning Feedback High</b>          Value of 4-56–4,999.000 * 4,999.000  <b>4-58 Missing Motor Phase Function</b>          [0] Off          *[1] On  <b>4-6*</b>  <b>4-61 From [Hz]</b>          0.0–400.0 Hz * 0.0 Hz  <b>4-63 To [Hz]</b>          0.0–400.0 Hz * 0.0 Hz  <b>5-1* Digital Inputs</b>  <b>5-10 Terminal 18 Digital Input</b>          [0] No function          [1] Reset          [2] Coast inverse          [3] Coast and reset inv.          [4] Quick stop inverse          [5] DC brake inv.          [6] Stop inv          *[8] Start          [9] Latched start          [10] Reversing          [11] Start reversing          [12] Enable start forward          [13] Enable start reverse          [14] Jog          [16–18] Preset ref bit 0-2          [19] Freeze reference</p>	<p><b>5-10 Terminal 18 Digital Input</b>          [20] Freeze output          [21] Speed up          [22] Slow          [23] Set-up select bit 0          [28] Catch up          [29] Slow-down          [34] Ramp bit 0          [60] Counter A (up)          [61] Counter A (down)          [62] Reset counter A          [63] Counter B (up)          [64] Counter B (down)          [65] ResetCounter B  <b>5-11 Terminal 19 Digital Input</b>          See par. 5-10. * [10] Reversing  <b>5-12 Terminal 27 Digital Input</b>          See par. 5-10. * [1] Reset  <b>5-13 Terminal 29 Digital Input</b>          See par. 5-10. * [14] Jog  <b>5-15 Terminal 33 Digital Input</b>          See par. 5-10. * [16] Preset ref bit 0          [26] Precise Stop Inverse          [27] Start, Precise Stop          [32] Pulse Input  <b>5-3* Digital Outputs</b>  <b>5-34 On Delay, Terminal 42 Digital Output</b>          0.00–600.00 s * 0.01 s  <b>5-35 Off Delay, Terminal 42 Digital Output</b>          0.00–600.00 s * 0.01 s  <b>5-4* Relays</b>  <b>5-40 Function Relay</b>          *[0] No operation          [1] Control ready          [2] Drive ready          [3] Drive ready, Remote          [4] Enable / No warning          [5] Drive running          [6] Running / No warning          [7] Run in range / No warning          [8] Run on ref / No warning          [9] Alarm          [10] Alarm or warning          [12] Out of current range          [13] Below current, low          [14] Above current, high          [16] Below frequency, low          [17] Above frequency, high          [19] Below feedback, low          [20] Above feedback, high          [21] Thermal warning          [22] Ready, No thermal warning          [23] Remote ready, No thermal warning          [24] Ready, Voltage ok          [25] Reverse          [26] Bus ok          [28] Brake, NoWarn          [29] Brake ready/NoFault          [30] BrakeFault (IGBT)          [32] Mech.brake control          [36] Control word bit 11          [41] Below reference, low          [42] Above reference, high          [51] Local ref. active</p>	<p><b>5-40 Function Relay</b>          [52] Remote ref. active          [53] No alarm          [54] Start cmd active          [55] Running reverse          [56] Drive in hand mode          [57] Drive in auto mode          [60–63] Comparator 0-3          [70–73] Logic rule 0-3  <b>5-41 On Delay, Relay</b>          0.00–600.00 s * 0.01 s  <b>5-42 Off Delay, Relay</b>          0.00–600.00 s * 0.01 s  <b>5-5* Pulse Input</b>  <b>5-55 Terminal 33 Low Frequency</b>          20–4,999 Hz * 20 Hz  <b>5-56 Terminal 33 High Frequency</b>          21–5,000 Hz * 5,000 Hz  <b>5-57 Term. 33 Low Ref./Feedb. Value</b>          –4,999–4,999 * 0.000  <b>5-58 Term. 33 High Ref./Feedb. Value</b>          –4,999–4,999 * 50.000  <b>6-** Analog In/Out</b>  <b>6-0* Analog I/O Mode</b>  <b>6-00 Live Zero Timeout Time</b>          1-99 s * 10 s  <b>6-01 Live Zero Timeout Function</b>          *[0] Off          [1] Freeze output          [2] Stop          [3] Jogging          [4] Max. speed          [5] Stop and trip  <b>6-1* Analog Input 1</b>  <b>6-10 Terminal 53 Low Voltage</b>          0.00–9.99 V * 0.07 V  <b>6-11 Terminal 53 High Voltage</b>          0.01–10.00 V * 10.00 V  <b>6-12 Terminal 53 Low Current</b>          0.00–19.99 mA * 0.14 mA  <b>6-13 Terminal 53 High Current</b>          0.01–20.00 mA * 20.00 mA  <b>6-14 Term. 53 Low Ref./Feedb. Value</b>          –4,999–4,999 * 0.000  <b>6-15 Term. 53 High Ref./Feedb. Value</b>          –4,999–4,999 * 50.000  <b>6-16 Terminal 53 Filter Time Constant</b>          0.01–10.00 s * 0.01 s  <b>6-19 Terminal 53 mode</b>          *[0] Voltage mode          [1] Current mode</p>	<p><b>6-2* Analog Input 2</b>  <b>6-22 Terminal 60 Low Current</b>          0.00–19.99 mA * 0.14 mA  <b>6-23 Terminal 60 High Current</b>          0.01–20.00 mA * 20.00 mA  <b>6-24 Term. 60 Low Ref./Feedb. Value</b>          –4,999–4,999 * 0.000  <b>6-25 Term. 60 High Ref./Feedb. Value</b>          –4,999–4,999 * 50.00  <b>6-26 Terminal 60 Filter Time Constant</b>          0.01–10.00 s * 0.01 s  <b>6-8* LCP Potentiometer</b>  <b>6-80 LCP Potmeter Enable</b>          [0] Disabled          *[1] Enable  <b>6-81 LCP potm. Low Reference</b>          –4,999–4,999 * 0.000  <b>6-82 LCP potm. High Reference</b>          –4,999–4,999 * 50.00  <b>6-9* Analog Output xx</b>  <b>6-90 Terminal 42 Mode</b>          *[0] 0–20 mA          [1] 4–20 mA          [2] Digital Output  <b>6-91 Terminal 42 Analog Output</b>          *[0] No operation          [10] Output Frequency          [11] Reference          [12] Feedback          [13] Motor Current          [16] Power          [19] DC Link Voltage          [20] Bus Reference  <b>6-92 Terminal 42 Digital Output</b>          See par. 5-40          *[0] No Operation  <b>6-93 Terminal 42 Output Min Scale</b>          0.00–200.0% * 0.00%  <b>6-94 Terminal 42 Output Max Scale</b>          0.00–200.0% * 100.0%  <b>7-** Controllers</b>  <b>7-2* Process Ctrl. Feedb</b>  <b>7-20 Process CL Feedback 1 Resource</b>          *[0] NoFunction          [1] Analog Input 53          [2] Analog input 60          [8] PulseInput33          [11] LocalBusRef</p>
--------------------------------------------------------------------------------------------------------------------------------------------------------------------------------------------------------------------------------------------------------------------------------------------------------------------------------------------------------------------------------------------------------------------------------------------------------------------------------------------------------------------------------------------------------------------------------------------------------------------------------------------------------------------------------------------------------------------------------------------------------------------------------------------------------------------------------------------------------------------------------------------------------------------------------------------------------------------------------------------------------------------------------------------------------------------------------------------------------------------------------------------------------------------------------------------------------------------------------------------------------------------------------------------------------------------------------------------------------------------------------------------------------------------------------------------------------------------------------------------------------------------------------------------------------------------------------------------------------------------------------------------------------------------------------------------------------------------------------------------------------------------------------------------------------------------------------------------------------------------------------------------------------------------------------------------------------------------------------------------------------------------------------------------------------------------------------------------------------------------------------------------------------	--------------------------------------------------------------------------------------------------------------------------------------------------------------------------------------------------------------------------------------------------------------------------------------------------------------------------------------------------------------------------------------------------------------------------------------------------------------------------------------------------------------------------------------------------------------------------------------------------------------------------------------------------------------------------------------------------------------------------------------------------------------------------------------------------------------------------------------------------------------------------------------------------------------------------------------------------------------------------------------------------------------------------------------------------------------------------------------------------------------------------------------------------------------------------------------------------------------------------------------------------------------------------------------------------------------------------------------------------------------------------------------------------------------------------------------------------------------------------------------------------------------------------------------------------------------------------------------------------------------------------------------------------------------------------------------------------------------------------------------------------------------------------------------------------------------------------------------------------------------------------------------------------------------------------------------------------------------------------------------------------------------------------------------------------------------------------------------------------------------------------------------------------------------------------------------------------------------------------------------------------------------------------------------------------------------------------------------------------------------------------------------------------------------------------------	---------------------------------------------------------------------------------------------------------------------------------------------------------------------------------------------------------------------------------------------------------------------------------------------------------------------------------------------------------------------------------------------------------------------------------------------------------------------------------------------------------------------------------------------------------------------------------------------------------------------------------------------------------------------------------------------------------------------------------------------------------------------------------------------------------------------------------------------------------------------------------------------------------------------------------------------------------------------------------------------------------------------------------------------------------------------------------------------------------------------------------------------------------------------------------------------------------------------------------------------------------------------------------------------------------------------------------------------------------------------------------------------------------------------------------------------------------------------------------------------------------------------------------------------------------------------------------------------------------------------------------------------------------------------------------------------------------------------------------------------------------------------------------------------------------------------------------------------------------------------------------------------------	----------------------------------------------------------------------------------------------------------------------------------------------------------------------------------------------------------------------------------------------------------------------------------------------------------------------------------------------------------------------------------------------------------------------------------------------------------------------------------------------------------------------------------------------------------------------------------------------------------------------------------------------------------------------------------------------------------------------------------------------------------------------------------------------------------------------------------------------------------------------------------------------------------------------------------------------------------------------------------------------------------------------------------------------------------------------------------------------------------------------------------------------------------------------------------------------------------------------------------------------------------------------------------------------------------------------------------------------------------------------------------------------------------------------------------------------------------------------------------------------------------------------------------------------------------------------------------------------------------------------------------------------------------------------------------------------------------------------------------------------------

<p><b>7-3* Process PI</b> Ctrl. 7-30 Process PI Normal/ Inverse Ctrl *[0] Normal [1] Inverse <b>7-31 Process PI Anti Windup</b> [0] Disable *[1] Enable <b>7-32 Process PI Start Speed</b> 0.0–200.0 Hz * 0.0 Hz <b>7-33 Process PI Proportional Gain</b> 0.00–10.00 * 0.01 <b>7-34 Process PI Integral Time</b> 0.10–9,999 s * 9,999 s <b>7-38 Process PI Feed Forward Factor</b> 0–400% * 0% <b>7-39 On Reference Bandwidth</b> 0–200% * 5% <b>8-** Comm. and Options</b> <b>8-0* General Settings</b> <b>8-01 Control Site</b> *[0] Digital and ControlWord [1] Digital only [2] ControlWord only <b>8-02 Control Word Source</b> [0] None *[1] RS485 <b>8-03 Control Word Timeout Time</b> 0.1–6500 s * 1.0 s <b>8-04 Control Word Timeout Function</b> *[0] Off [1] Freeze Output [2] Stop [3] Jogging [4] Max. Speed [5] Stop and trip <b>8-06 Reset Control Word Timeout</b> *[0] No Function [1] Do reset <b>8-3* Port Settings</b> <b>8-30 Protocol</b> *[0] [2] Modbus <b>8-31 Address</b> 1–247 * 1 <b>8-32 Port Baud Rate</b> [0] 2400 Baud [1] 4800 Baud *[2] 9600 Baud For choose FC Bus in 8-30 *[3] 19200 Baud For choose Modbus in 8-30 [4] 38400 Baud <b>8-33 Port Parity</b> *[0] Even Parity, 1 Stop Bit [1] Odd Parity, 1 Stop Bit [2] No Parity, 1 Stop Bit [3] No Parity, 2 Stop Bits <b>8-35 Minimum Response Delay</b> 0.001–0.5 * 0.010 s <b>8-36 Max Response Delay</b> 0.100–10.00 s * 5.000 s</p>	<p><b>8-4* FC MC protocol set</b> <b>8-43 FC Port PCD Read Configuration</b> *[0] None Expressionlimit [1] [1500] Operation Hours [2] [1501] Running Hours [3] [1502] kWh Counter [4] [1600] Control Word [5] [1601] Reference [Unit] [6] [1602] Reference % [7] [1603] Status Word [8] [1605] Main Actual Value [%] [9] [1609] Custom Readout [10] [1610] Power [kW] [11] [1611] Power [hp] [12] [1612] Motor Voltage [13] [1613] Frequency [14] [1614] Motor Current [15] [1615] Frequency [%] [16] [1618] Motor Thermal [17] [1630] DC Link Voltage [18] [1634] Heatsink Temp. [19] [1635] Inverter Thermal [20] [1638] SL Controller State [21] [1650] External Reference [22] [1651] Pulse Reference [23] [1652] Feedback [Unit] [24] [1660] Digital Input 18,19,27,33 [25] [1661] Digital Input 29 [26] [1662] Analog Input 53 (V) [27] [1663] Analog Input 53 (mA) [28] [1664] Analog Input 60 [29] [1665] Analog Output 42 [mA] [30] [1668] Freq. Input 33 [Hz] [31] [1671] Relay Output [bin] [32] [1672] Counter A [33] [1673] Counter B [34] [1690] Alarm Word [35] [1692] Warning Word [36] [1694] Ext. Status Word <b>8-5* Digital/Bus</b> <b>8-50 Coasting Select</b> [0] DigitalInput [1] Bus [2] LogicAnd *[3] LogicOr <b>8-51 Quick Stop Select</b> See par. 8-50 * [3] LogicOr <b>8-52 DC Brake Select</b> See par. 8-50 * [3] LogicOr <b>8-53 Start Select</b> See par. 8-50 * [3] LogicOr <b>8-54 Reversing Select</b> See par. 8-50 * [3] LogicOr <b>8-55 Set-up Select</b> See par. 8-50 * [3] LogicOr <b>8-56 Preset Reference Select</b> See par. 8-50 * [3] LogicOr <b>8-8* Bus Communication Diagnostics</b> <b>8-80 Bus Message Count</b> 0–0 N/A * 0 N/A <b>8-81 Bus Error Count</b> 0–0 N/A * 0 N/A <b>8-82 Slave Messages Rcvd</b> 0–0 N/A * 0 N/A <b>8-83 Slave Error Count</b> 0–0 N/A * 0 N/A</p>	<p><b>8-9* Bus Jog / Feedback</b> <b>8-94 Bus feedback 1</b> 0x8000–0x7FFF * 0 <b>13-** Logic</b> <b>13-0* Settings</b> <b>13-00</b> *[0] Off [1] On <b>13-01 Start Event</b> [0] False [1] True [2] Running [3] InRange [4] OnReference [7] OutOfCurrentRange [8] BelowLow [9] AboveHigh [16] ThermalWarning [17] MainOutOfRange [18] Reversing [19] Warning [20] Alarm_Trip [21] Alarm_TripLock [22–25] Comparator 0-3 [26–29] LogicRule0-3 [33] DigitalInput_18 [34] DigitalInput_19 [35] DigitalInput_27 [36] DigitalInput_29 [38] DigitalInput_33 *[39] StartCommand [40] DriveStopped <b>13-02 Stop Event</b> See par. 13-01 * [40] DriveStopped <b>13-03 Reset</b> *[0] Do not reset [1] Reset <b>13-1* Comparators</b> <b>13-10 Comparator Operand</b> *[0] Disabled [1] Reference [2] Feedback [3] MotorSpeed [4] MotorCurrent [6] MotorPower [7] MotorVoltage [8] DCLinkVoltage [12] AnalogInput53 [13] AnalogInput60 [18] PulseInput33 [20] AlarmNumber [30] CounterA [31] CounterB <b>13-11 Comparator Operator</b> [0] Less Than *[1] Approximately equals [2] Greater Than <b>13-12 Comparator Value</b> –9,999–9,999 * 0.0 <b>13-2* Timers</b> <b>13-20 Controller Timer</b> 0.0–3,600 s * 0.0 s</p>	<p><b>13-4* Logic Rules</b> <b>13-40 Logic Rule Boolean 1</b> See par. 13-01 *[0] False [30] - [32] Timeout 0-2 <b>13-41 Logic Rule Operator 1</b> *[0] Disabled [1] And [2] Or [3] And not [4] Or not [5] Not and [6] Not or [7] Not and not [8] Not or not <b>13-42 Logic Rule Boolean 2</b> See par. 13-40 * [0] False <b>13-43 Logic Rule Operator 2</b> See par. 13-41 *[0] Disabled <b>13-44 Logic Rule Boolean 3</b> See par. 13-40 * [0] False <b>13-5* States</b> <b>13-51 Controller Event</b> See par. 13-40 *[0] False <b>13-52 Controller Action</b> *[0] Disabled [1] NoAction [2] SelectSetup1 [3] SelectSetup2 [10–17] SelectPresetRef0-7 [18] [19] [22] Run [23] RunReverse [24] Stop [25] Qstop [26] DCstop [27] Coast [28] FreezeOutput [29] StartTimer0 [30] StartTimer1 [31] StartTimer2 [32] Set Digital Output A Low [33] Set Digital Output B Low [38] Set Digital Output A High [39] Set Digital Output B High [60] ResetCounterA [61] ResetCounterB <b>14-** Special Functions</b> <b>14-0*</b> <b>14-01</b> [0] 2 kHz *[1] 4 kHz [2] 8 kHz [4] 16 kHz not available for M5 <b>14-03 Overmodulation</b> [0] Off *[1] On <b>14-1* Line power monitoring</b> <b>14-12 Function at line imbalance</b> *[0] Trip [1] Warning [2] Disabled</p>
----------------------------------------------------------------------------------------------------------------------------------------------------------------------------------------------------------------------------------------------------------------------------------------------------------------------------------------------------------------------------------------------------------------------------------------------------------------------------------------------------------------------------------------------------------------------------------------------------------------------------------------------------------------------------------------------------------------------------------------------------------------------------------------------------------------------------------------------------------------------------------------------------------------------------------------------------------------------------------------------------------------------------------------------------------------------------------------------------------------------------------------------------------------------------------------------------------------------------------------------------------------------------------------------------------------------------------------------------------------------------------------------------------------------------------------------------------------------------------------------------------------------------------------------------------------------------------------------------------------------------------------------------------------------------	--------------------------------------------------------------------------------------------------------------------------------------------------------------------------------------------------------------------------------------------------------------------------------------------------------------------------------------------------------------------------------------------------------------------------------------------------------------------------------------------------------------------------------------------------------------------------------------------------------------------------------------------------------------------------------------------------------------------------------------------------------------------------------------------------------------------------------------------------------------------------------------------------------------------------------------------------------------------------------------------------------------------------------------------------------------------------------------------------------------------------------------------------------------------------------------------------------------------------------------------------------------------------------------------------------------------------------------------------------------------------------------------------------------------------------------------------------------------------------------------------------------------------------------------------------------------------------------------------------------------------------------------------------------------------------------------------------------------------------------------------------------------------------------------------------------------------------------------------------------------------------------------------------------------------------------------------------------------------------------------------------------------------------------------------------------------------------------------------------	-------------------------------------------------------------------------------------------------------------------------------------------------------------------------------------------------------------------------------------------------------------------------------------------------------------------------------------------------------------------------------------------------------------------------------------------------------------------------------------------------------------------------------------------------------------------------------------------------------------------------------------------------------------------------------------------------------------------------------------------------------------------------------------------------------------------------------------------------------------------------------------------------------------------------------------------------------------------------------------------------------------------------------------------------------------------------------------------------------------------------------------------------------------------------------------------------------------------------------------------------------------------------------------------------------------------------------------------------------------------------------------------------------------------------------------------------------------------------	-------------------------------------------------------------------------------------------------------------------------------------------------------------------------------------------------------------------------------------------------------------------------------------------------------------------------------------------------------------------------------------------------------------------------------------------------------------------------------------------------------------------------------------------------------------------------------------------------------------------------------------------------------------------------------------------------------------------------------------------------------------------------------------------------------------------------------------------------------------------------------------------------------------------------------------------------------------------------------------------------------------------------------------------------------------------------------------------------------------------------------------------------------------------------------------------------------------------------------------------------------------------------------------------------------------------------------------------------------------------------------------------------------------------------------------------------------------------------------------------------------------------------

14-2* <i>Trip Reset</i> 14-20 <i>Reset Mode</i> *[0] Manual reset [1-9] AutoReset 1-9 [10] AutoReset 10 [11] AutoReset 15 [12] AutoReset 20 [13] infinite auto reset [14] Reset at power-up 14-21 <i>Automatic Restart Time</i> 0-600s * 10s *[0] Normal Operation [2] 14-26 <i>Action At Fault</i> *[0] Trip [1] Warning 14-4* <i>Energy</i> 14-41 <i>Minimum Magnetization</i> 40-75% * 66% 14-9* <i>Fault Settings</i> 14-90 <i>Fault level</i> [3] Trip Lock [4] Trip with delayed reset 15-** <i>Drive Information</i> 15-0* <i>Operating Data</i> 15-00 <i>Operating Days</i> 15-01 <i>Running Hours</i> 15-02 <i>kWh Counter</i> 15-03 <i>Power-ups</i> 15-04 <i>Overtemps</i>	15-05 <i>Overvolts</i> 15-06 <i>Reset kWh Counter</i> *[0] Do not reset [1] Reset counter 15-07 <i>Reset Running Hours Counter</i> *[0] Do not reset [1] Reset counter 15-3* <i>Fault Log</i> 15-30 <i>Fault Log: Error Code</i> 15-4* <i>Drive Identification</i> 15-40 <i>Type</i> 15-41 <i>Power Section</i> 15-42 <i>Voltage</i> 15-43 <i>Software Version</i> 15-46 <i>Adj. Freq. Drive Order. No</i> 15-48 <i>LCP Id No</i> 15-51 <i>Adj. Freq. Drive Serial No</i> 16-** <i>Data Readouts 16-0* General Status</i> 16-00 <i>Control Word</i> 0-0XFFFF 16-01 <i>Reference [Unit]</i> -4,999-4,999 * 0.000 16-02 <i>Reference %</i> -200.0-200.0% * 0.0% 16-03 <i>Status Word</i> 0-0XFFFF 16-05 <i>Main Actual Value [%]</i> -200.0-200.0% * 0.0% 16-09 <i>Custom Readout</i> Dep. on par. 0-31, 0-32	16-1* <i>Motor Status</i> 16-10 <i>Power [kW]</i> 16-11 <i>Power [hp]</i> 16-12 <i>Motor Voltage [V]</i> 16-13 <i>Frequency [Hz]</i> 16-14 <i>Motor Current [A]</i> 16-15 <i>Frequency [%]</i> 16-18 <i>Motor Thermal [%]</i> 16-3* <i>Drive Status</i> 16-30 <i>DC Link Voltage</i> 16-34 <i>Heatsink Temp.</i> 16-35 <i>Inverter Thermal</i> 16-36 16-37 16-38 16-5* <i>Ref./Feedb.</i> 16-50 <i>External Reference</i> 16-51 <i>Pulse Reference</i> 16-52 <i>Feedback [Unit]</i> 16-6* <i>Inputs/Outputs</i> 16-60 <i>Digital Input 18,19,27,33</i> 0-1111 16-61 <i>Digital Input 29</i> 0-1 16-62 <i>Analog Input 53 (volt)</i> 16-63 <i>Analog Input 53 (current)</i> 16-64 <i>Analog Input 60</i> 16-65 <i>Analog Output 42 [mA]</i> 16-68 <i>Pulse Input [Hz]</i>	16-71 <i>Relay Output [bin]</i> 16-72 <i>Counter A</i> 16-73 <i>Counter B</i> 16-8* <i>Ser Com Bus/ Port</i> 16-86 <i>Port REF 1</i> 0x8000-0x7FFFF 16-9* <i>Diagnosis Readouts</i> 16-90 <i>Alarm Word</i> 0-0XFFFFFFFF 16-92 <i>Warning Word</i> 0-0XFFFFFFFF 16-94 <i>Ext. Status Word</i> 0-0XFFFFFFFF 18-** <i>Extended Motor Data</i> 18-8* <i>Motor Resistors</i> 18-80 <i>Stator Resistance (High resolution)</i> 0.000-99.990 ohm * 0.000 ohm 18-81 <i>Stator Leakage Reactance (High resolution)</i> 0.000-99.990 ohm * 0.000 ohm
---------------------------------------------------------------------------------------------------------------------------------------------------------------------------------------------------------------------------------------------------------------------------------------------------------------------------------------------------------------------------------------------------------------------------------------------------------------------------------------------------------------------------------------------------------------------------------------------------------------------------------------------------------------------------------------------------------------------------------------------------------------------------	----------------------------------------------------------------------------------------------------------------------------------------------------------------------------------------------------------------------------------------------------------------------------------------------------------------------------------------------------------------------------------------------------------------------------------------------------------------------------------------------------------------------------------------------------------------------------------------------------------------------------------------------------------------------------------------------------------------------------------------------------------------------------------------------------------------------------------------------------------------------------------------------------	--------------------------------------------------------------------------------------------------------------------------------------------------------------------------------------------------------------------------------------------------------------------------------------------------------------------------------------------------------------------------------------------------------------------------------------------------------------------------------------------------------------------------------------------------------------------------------------------------------------------------------------------------------------------------------------------------------------------------------------------------------------------------------------------------------------------------------------------------------------	---------------------------------------------------------------------------------------------------------------------------------------------------------------------------------------------------------------------------------------------------------------------------------------------------------------------------------------------------------------------------------------------------------------------------------------------------------------------------------------------------------------------------------------------------------------------------------------------------



## 1.6 Troubleshooting

### 1.6.1 Warnings and Alarms

No.	Description	Warning	Alarm	Trip Lock	Error	Cause of Problem
2	Live zero error	X	X			Signal on terminal 53 or 60 is less than 50% of value set in 6-10 Terminal 53 Low Voltage, 6-12 Terminal 53 Low Current and 6-22 Terminal 54 Low Current.
4	Mains phase loss <sup>1)</sup>	X	X	X		Missing phase on the supply side, or a voltage imbalance that is too high. Check supply voltage.
7	DC overvoltage <sup>1)</sup>	X	X			Intermediate circuit voltage exceeds the limit.
8	DC undervoltage <sup>1)</sup>	X	X			Intermediate circuit voltage drops below the "voltage warning low" limit.
9	overloaded	X	X			More than 100% load for too long.
10	Motor overtemperature	X	X			Motor is too hot due to more than 100% load for too long.
11	Motor thermistor overtemp.	X	X			The thermistor or the thermistor connection is disconnected.
12	Torque limit	X				Torque exceeds value set in either parameter 4-16 Torque Limit Motor Mode or 4-17 Torque Limit Generator Mode.
13	Overcurrent	X	X	X		current limit is exceeded.
14	Ground fault	X	X	X		Discharge from output phases to ground.
16	Short circuit		X	X		Short-circuit in the motor or on the motor terminals.
17	Control word timeout	X	X			No communication to the adjustable frequency drive.
25	Brake resistor short-circuited		X	X		Brake resistor is short-circuited, thus the brake function is disconnected.
27	Brake chopper short-circuited		X	X		Brake transistor is short-circuited, thus the brake function is disconnected.
28	Brake check		X			Brake resistor is not connected/working
29	Power board overtemp	X	X	X		Heatsink cut-out temperature has been reached.
30	Motor phase U missing		X	X		Motor phase U is missing. Check the phase.
31	Motor phase V missing		X	X		Motor phase V is missing. Check the phase.
32	Motor phase W missing		X	X		Motor phase W is missing. Check the phase.
38	Internal fault		X	X		Contact local Danfoss supplier.
44	Ground fault		X	X		Discharge from output phases to ground.
47	Control Voltage Fault		X	X		24 V DC may be overloaded.
51	check $U_{nom}$ and $I_{nom}$		X			Wrong setting for motor voltage and/or motor current.
52	low $I_{nom}$		X			Motor current is too low. Check settings.
59	Current limit	X				overload.
63	Mechanical Brake Low		X			Actual motor current has not exceeded the "release brake" current in the "start delay" time window.
80			X			
84	The connection between drive and LCP is lost				X	No communication between LCP and adjustable frequency drive
85	Button disabled				X	See parameter group 0-4* 0-4* LCP
86	Copy fail				X	An error occurred while copying from adjustable frequency drive to LCP or vice versa.
87	LCP data invalid				X	Occurs when copying from LCP if the LCP contains erroneous data - or if no data was uploaded to the LCP.
88	LCP data not compatible				X	Occurs when copying from LCP if data are moved between adjustable frequency drives with major differences in software versions.
89	Parameter read-only				X	Occurs when trying to write to a read-only parameter.
90	Parameter database busy				X	LCP and RS485 connection are trying to update parameters simultaneously.
91	Parameter value is not valid in this mode				X	Occurs when trying to write an illegal value to a parameter.
92	Parameter value exceeds the min/max limits				X	Occurs when trying to set a value outside the range.
nw run	Not While RUNNING				X	Parameter can only be changed when the motor is stopped.
Err.	An incorrect password was entered				X	Occurs when using an incorrect password for changing a password-protected parameter.

<sup>1)</sup> These faults may be caused by line power distortions. Installing a Danfoss line filter may rectify this problem.

Table 1.6 Warnings and Alarms Code List

## 1.7 Specifications

### 1.7.1 Line Power Supply 1x200–240 V AC

Normal overload 150% for 1 minute					
Adjustable frequency drive					
Typical Shaft Output [kW]	0.18	0.37	0.75	1.5	2.2
Typical Shaft Output [HP]	0.25	0.5	1	2	3
IP20					
Output current					
Continuous (1x200–240 V AC) [A]	1.2	2.2	4.2	6.8	9.6
Intermittent (1x200–240 V AC) [A]	1.8	3.3	6.3	10.2	14.4
Max. cable size:					
(line power, motor) [mm <sup>2</sup> /AWG]	4/10				
Max. input current					
Continuous (1x200–240 V) [A]	3.3	6.1	11.6	18.7	26.4
Intermittent (1x200–240 V) [A]	4.5	8.3	15.6	26.4	37.0
Max. electrical fuses [A]	See chapter 1.3.4 Fuses				
Environment					
Estimated power loss [W], Best case/Typical <sup>1)</sup>	12.5/ 15.5	20.0/ 25.0	36.5/ 44.0	61.0/ 67.0	81.0/ 85.1
Weight enclosure IP20 [kg]	1.1	1.1	1.1	1.6	3.0
Efficiency [%], Best case/Typical <sup>1)</sup>	95.6/ 94.5	96.5/ 95.6	96.6/ 96.0	97.0/ 96.7	96.9/ 97.1

Table 1.7 Line Power Supply 1x200–240 V AC

<sup>1)</sup> At rated load conditions

### 1.7.2 Line Power Supply 3x200–240 V AC

Normal overload 150% for 1 min						
Adjustable frequency drive						
Typical Shaft Output [kW]	0.25	0.37	0.75	1.5	2.2	3.7
Typical Shaft Output [HP]	0.33	0.5	1	2	3	5
IP20						
Output current						
Continuous (3x200–240 V) [A]	1.5	2.2	4.2	6.8	9.6	15.2
Intermittent (3x200–240 V) [A]	2.3	3.3	6.3	10.2	14.4	22.8
Max. cable size:						
(line power, motor) [mm <sup>2</sup> /AWG]	4/10					
Max. input current						
Continuous (3x200–240 V) [A]	2.4	3.5	6.7	10.9	15.4	24.3
Intermittent (3x200–240 V) [A]	3.2	4.6	8.3	14.4	23.4	35.3
Max. electrical fuses [A]	See chapter 1.3.4 Fuses					
Environment						
Estimated power loss [W], Best case/Typical <sup>1)</sup>	14.0/ 20.0	19.0/ 24.0	31.5/ 39.5	51.0/ 57.0	72.0/ 77.1	115.0/ 122.8
Weight enclosure IP20 [kg]	1.1	1.1	1.1	1.6	3.0	3.0
Efficiency [%], Best case/Typical <sup>1)</sup>	96.4/ 94.9	96.7/ 95.8	97.1/ 96.3	97.4/ 97.2	97.2/ 97.4	97.3/ 97.4

Table 1.8 Line Power Supply 3x200–240 V AC

<sup>1)</sup> At rated load conditions.

### 1.7.3 Line Power Supply 3x380–480 V AC

Normal overload 150% for 1 minute						
Adjustable frequency drive	0.37	0.75	1.5	2.2	3.0	4.0
Typical Shaft Output [kW]						
Typical Shaft Output [HP]	0.5	1	2	3	4	5
IP20						
Output current						
Continuous (3x380–440 V) [A]	1.2	2.2	3.7	5.3	7.2	9.0
Intermittent (3x380–440 V) [A]	1.8	3.3	5.6	8.0	10.8	13.7
Continuous (3x440–480 V) [A]	1.1	2.1	3.4	4.8	6.3	8.2
Intermittent (3x440–480 V) [A]	1.7	3.2	5.1	7.2	9.5	12.3
Max. cable size:						
(line power, motor) [mm <sup>2</sup> /AWG]	4/10					
Max. input current						
Continuous (3x380–440 V) [A]	1.9	3.5	5.9	8.5	11.5	14.4
Intermittent (3x380–440 V) [A]	2.6	4.7	8.7	12.6	16.8	20.2
Continuous (3x440–480 V) [A]	1.7	3.0	5.1	7.3	9.9	12.4
Intermittent (3x440–480 V) [A]	2.3	4.0	7.5	10.8	14.4	17.5
Max. electrical fuses [A]	See chapter 1.3.4 Fuses					
Environment						
Estimated power loss [W]	18.5/	28.5/	41.5/	57.5/	75.0/	98.5/
Best case/Typical <sup>1)</sup>	25.5	43.5	56.5	81.5	101.6	133.5
Weight enclosure IP20 [kg]	1.1	1.1	1.6	1.6	3.0	3.0
Efficiency [%]	96.8/	97.4/	98.0/	97.9/	98.0/	98.0/
Best case/Typical <sup>1)</sup>	95.5	96.0	97.2	97.1	97.2	97.3

**Table 1.9 Line Power Supply 3x380–480 V AC**

1. At rated load conditions.

Normal overload 150% for 1 minute						
Adjustable frequency drive	5.5	7.5	11	15	18.5	22
Typical Shaft Output [kW]						
Typical Shaft Output [HP]	7.5	10	15	20	25	30
IP20						
Output current						
Continuous (3x380–440 V) [A]	12.0	15.5	23.0	31.0	37.0	43.0
Intermittent (3x380–440 V) [A]	18.0	23.5	34.5	46.5	55.5	64.5
Continuous (3x440–480 V) [A]	11.0	14.0	21.0	27.0	34.0	40.0
Intermittent (3x440–480 V) [A]	16.5	21.3	31.5	40.5	51.0	60.0
Max. cable size:						
(line power, motor) [mm <sup>2</sup> /AWG]	4/10		16/6			
Max. input current						
Continuous (3x380–440 V) [A]	19.2	24.8	33.0	42.0	34.7	41.2
Intermittent (3x380–440 V) [A]	27.4	36.3	47.5	60.0	49.0	57.6
Continuous (3x440–480 V) [A]	16.6	21.4	29.0	36.0	31.5	37.5
Intermittent (3x440–480 V) [A]	23.6	30.1	41.0	52.0	44.0	53.0
Max. electrical fuses [A]	See chapter 1.3.4 Fuses					
Environment						
Estimated power loss [W]	131.0/	175.0/	290.0/	387.0/	395.0/	467.0/
Best case/Typical <sup>1)</sup>	166.8	217.5	342.0	454.0	428.0	520.0
Weight enclosure IP20 [kg]	3.0	3.0				
Efficiency [%]	98.0/	98.0/	97.8/	97.7/	98.1/	98.1/
Best case/Typical <sup>1)</sup>	97.5	97.5	97.4	97.4	98.0	97.9

**Table 1.10 Line Power Supply 3x380–480 V AC**

1. At rated load conditions.

## 1.8 General Technical Data

### Protection and features

- Electronic thermal motor protection against overload.
- Temperature monitoring of the heatsink ensures that the adjustable frequency drive trips in case of overtemperature.
- The adjustable frequency drive is protected against short-circuits between motor terminals U, V, W.
- When a motor phase is missing, the adjustable frequency drive trips and issues an alarm.
- When a line phase is missing, the adjustable frequency drive trips or issues a warning (depending on the load).
- Monitoring of the intermediate circuit voltage ensures that the adjustable frequency drive trips when the intermediate circuit voltage is too low or too high.
- The adjustable frequency drive is protected against ground faults on motor terminals U, V, W.

### Line power supply (L1/L, L2, L3/N)

Supply voltage	200–240 V $\pm 10\%$
Supply voltage	380–480 V $\pm 10\%$
Supply frequency	50/60 Hz
Max. temporary imbalance between line phases	3.0% of rated supply voltage
True Power Factor	$\geq 0.4$ nominal at rated load
Displacement Power Factor ( $\cos\phi$ ) near unity	(>0.98)
Switching on input supply L1/L, L2, L3/N (power-ups)	maximum 2 times/min.
Environment according to EN60664-1	Overvoltage category III/pollution degree 2

*The unit is suitable for use on a circuit capable of delivering not more than 100,000 RMS symmetrical Amperes, 240/480 V maximum.*

### Motor output (U, V, W)

Output voltage	0–100% of supply voltage
Output frequency	0–200 Hz (VVC <sup>plus</sup> ), 0–400 Hz (u/f)
Switching on output	Unlimited
Ramp times	0.05–3,600 s

### Cable lengths and cross-sections

Max. motor cable length, shielded/armored (EMC-compatible installation)	50 ft [15 m]
Max. motor cable length, non-shielded/unarmored	164 ft [50 m]
Max. cross-section to motor, line power*	
Connection to load sharing/brake (M1, M2, M3)	0.25 in [6.3 mm] insulated Faston plugs
Max. cross-section to load sharing/brake (M4, M5)	16 mm <sup>2</sup> /6 AWG
Maximum cross-section to control terminals, rigid wire	1.5 mm <sup>2</sup> /16 AWG (2x0.75 mm <sup>2</sup> )
Maximum cross-section to control terminals, flexible cable	1 mm <sup>2</sup> /18 AWG
Maximum cross-section to control terminals, cable with enclosed core	0.5 mm <sup>2</sup> /20 AWG
Minimum cross-section to control terminals	0.00039 in <sup>2</sup> [0.25 mm <sup>2</sup> ]

\* See chapter 1.7 Specifications for more information!

## Digital inputs (pulse/encoder inputs)

Programmable digital inputs (pulse/encoder)	5 (1)
Terminal number	18, 19, 27, 29, 33,
Logic	PNP or NPN
Voltage level	0–24 V DC
Voltage level, logic '0' PNP	<5 V DC
Voltage level, logic '1' PNP	>10 V DC
Voltage level, logic '0' NPN	>19 V DC
Voltage level, logic '1' NPN	<14 V DC
Maximum voltage on input	28 V DC
Input resistance, $R_i$	approx. 4 k $\Omega$
Max. pulse frequency at terminal 33	5,000 Hz
Min. pulse frequency at terminal 33	20 Hz

## Analog inputs

Number of analog inputs	2
Terminal number	53, 60
Voltage mode (Terminal 53)	Switch S200=OFF(U)
Current mode (Terminal 53 and 60)	Switch S200=ON(I)
Voltage level	0–10 V
Input resistance, $R_i$	approx. 10 k $\Omega$
Max. voltage	20 V
Current level	0/4 to 20 mA (scaleable)
Input resistance, $R_i$	approx. 200 $\Omega$
Max. current	30 mA

## Analog output

Number of programmable analog outputs	1
Terminal number	42
Current range at analog output	0/4–20 mA
Max. load to common at analog output	500 $\Omega$
Max. voltage at analog output	17 V
Accuracy on analog output	Max. error: 0.8% of full scale
Scan interval	4 ms
Resolution on analog output	8 bit
Scan interval	4 ms

## Control card, RS-485 serial communication

Terminal number	68 (P,TX+, RX+), 69 (N,TX-, RX-)
Terminal number 61	Common for terminals 68 and 69

## Control card, 24 V DC output

Terminal number	12
Max. load (M1 and M2)	100 mA
Max. load (M3)	50 mA
Max. load (M4 and M5)	80 mA

## Relay output

Programmable relay output	1
Relay 01 Terminal number	01-03 (break), 01-02 (make)
Max. terminal load (AC-1) <sup>1)</sup> on 01-02 (NO) (resistive load)	250 V AC, 2 A
Max. terminal load (AC-15) <sup>1)</sup> on 01-02 (NO) (Inductive load @ cosφ 0.4)	250 V AC, 0.2 A
Max. terminal load (DC-1) <sup>1)</sup> on 01-02 (NO) (resistive load)	30 V DC, 2 A
Max. terminal load (DC-13) <sup>1)</sup> on 01-02 (NO) (inductive load)	24 V DC, 0.1 A
Max. terminal load (AC-1) <sup>1)</sup> on 01-03 (NC) (resistive load)	250 V AC, 2 A
Max. terminal load (AC-15) <sup>1)</sup> on 01-03 (NC) (Inductive load @ cosφ 0.4)	250 V AC, 0.2 A
Max. terminal load (DC-1) <sup>1)</sup> on 01-03 (NC) (resistive load)	30 V DC, 2 A
Min. terminal load on 01-03 (NC), 01-02 (NO)	24 V DC 10 mA, 24 V AC 20 mA
Environment according to EN 60664-1	Overvoltage category III/pollution degree 2

<sup>1)</sup> IEC 60947 part 4 and 5

## Control card, 10 V DC output

Terminal number	50
Output voltage	10.5 V ±0.5 V
Max. load	25 mA

**NOTICE!**

All inputs, outputs, circuits, DC supplies and relay contacts are galvanically isolated from the supply voltage (PELV) and other high-voltage terminals.

## Surroundings

Enclosure	IP20
Enclosure kit available.	IP21, TYPE 1
Vibration test	1.0 g
Max. relative humidity	5–95% (IEC 60721-3-3); Class 3K3 (non-condensing) during operation
Aggressive environment (IEC 60721-3-3), coated	class 3C3
Test method according to IEC 60068-2-43 H2S (10 days)	
Ambient temperature	Max. 104°F [40°C]

*Derating for high ambient temperature, see chapter 1.9.1 Derating for Ambient Temperature*

Minimum ambient temperature during full-scale operation	32°F [0°C]
Minimum ambient temperature at reduced performance	14° [-10°C]
Temperature during storage/transport	-13°–+149/158°F [-25°–+65/70°C]
Maximum altitude above sea level without derating	3300 ft [1000 m]
Maximum altitude above sea level with derating	10,000 ft [3000 m]

*Derating for high altitude, see chapter 1.9 Special Conditions*

Safety standards	EN/IEC 61800-5-1, UL 508C
EMC standards, Emission	EN 61800-3, EN 61000-6-3/4, EN 55011, IEC 61800-3 EN 61800-3, EN 61000-6-1/2, EN 61000-4-2, EN 61000-4-3,
EMC standards, Immunity	EN 61000-4-4, EN 61000-4-5, EN 61000-4-6

*See chapter 1.9 Special Conditions*

## 1.9 Special Conditions

### 1.9.1 Derating for Ambient Temperature

The ambient temperature measured over 24 hours should be at least 9°F [5°C] lower than the max. ambient temperature.

If the adjustable frequency drive is operated at a high ambient temperature, the continuous output current should be decreased.

The adjustable frequency drive has been designed for operation at max 122°F [50°C] ambient temperature with one motor size smaller than nominal. Continuous operation at full load at 122°F [50°C] ambient temperature will reduce the lifetime of the adjustable frequency drive.

### 1.9.2 Derating for Low Air Pressure

The cooling capability of air is decreased at low air pressure.

For altitudes above 6,600 ft [2,000 m], contact Danfoss.

Below 3,300 ft [1,000 m] altitude, no de-rating is necessary, but above 3,300 ft [1,000 m], the ambient temperature or the maximum output current should be decreased.

Decrease the output by 1% per 330 ft [100 m] altitude above 3,300 ft [1,000 m] or reduce the max. ambient temperature by 1° per 660 ft [200 m].

### 1.9.3 Derating for Running at Low Speeds

When a motor is connected to an adjustable frequency drive, check that the cooling of the motor is adequate. A problem may occur at low speeds in constant torque applications. Running continuously at low speeds – below half the nominal motor speed – may require additional air cooling. Alternatively, select a larger motor (one size up).

## 1.10 Options

Ordering No	Description
132B0100	VLT Control Panel LCP 11 w/o potentiometer
132B0101	VLT Control Panel LCP 12 with potentiometer
132B0102	Remote Mounting Kit for LCP incl. 3 m cable IP55 with LCP 11, IP21 with LCP 12
132B0103	Nema Type 1 kit for enclosure type M1
132B0104	Type 1 kit for enclosure type M2
132B0105	Type 1 kit for enclosure type M3
132B0106	De-coupling plate kit for enclosure type M1 and M2
132B0107	De-coupling plate kit for enclosure type M3
132B0108	IP21 for enclosure type M1
132B0109	IP21 for enclosure type M2
132B0110	IP21 for frame M3
132B0111	DIN rail mounting kit for enclosure types M1 and M2
132B0120	Type 1 kit for enclosure type M4
132B0121	Type 1 kit for enclosure type M5
132B0122	De-coupling plate kit for enclosure types M4 and M5
132B0126	Enclosure type M1 spare parts kits
132B0127	Enclosure type M2 spare parts kits
132B0128	Enclosure type M3 spare parts kits
132B0129	Enclosure type M4 spare parts kits
132B0130	Enclosure type M5 spare parts kits
132B0131	Blank cover
130B2522	MCC 107 filter for 132F0001
130B2522	MCC 107 filter for 132F0002
130B2533	MCC 107 filter for 132F0003
130B2525	MCC 107 filter for 132F0005
130B2530	MCC 107 filter for 132F0007
130B2523	MCC 107 filter for 132F0008
130B2523	MCC 107 filter for 132F0009
130B2523	MCC 107 filter for 132F0010
130B2526	MCC 107 filter for 132F0012
130B2531	MCC 107 filter for 132F0014
130B2527	MCC 107 filter for 132F0016
130B2523	MCC 107 filter for 132F0017
130B2523	MCC 107 filter for 132F0018
130B2524	MCC 107 filter for 132F0020
130B2526	MCC 107 filter for 132F0022
130B2529	MCC 107 filter for 132F0024
130B2531	MCC 107 filter for 132F0026
130B2528	MCC 107 filter for 132F0028
130B2527	MCC 107 filter for 132F0030

Table 1.11

Danfoss line filters and brake resistors are available upon request.



**Index**

<b>A</b>		<b>L</b>	
Active Set-up.....	11	Line power supply.....	16
Ambient temperature.....	20	Line power supply (L1/L, L2, L3/N).....	18
Analog inputs.....	19	Line power supply 1x200–240 V AC.....	16
<b>B</b>		Line power supply 3x200–240 V AC.....	16
Brake Resistor (ohm).....	11	Line power supply 3x380–480 V AC.....	17
Brake resistor short-circuited.....	15	Load Compensation.....	11
<b>C</b>		Load Sharing/Brake.....	9
Cable lengths and cross-sections.....	18	<b>M</b>	
Clearance.....	4	Main Menu.....	9
Control card, 24 V DC output.....	19	Motor output (U, V, W).....	18
<b>D</b>		Motor overload protection.....	3
DC brake.....	12	Motor Phase.....	12
DC Brake.....	11	Motor protection.....	18
Derating for ambient temperature.....	21	Motor Temperature.....	11
Derating for low air pressure.....	21	<b>N</b>	
Derating for running at low speeds.....	21	Navigation Keys.....	9
Digital inputs.....	19	<b>O</b>	
Digital inputs (pulse/encoder inputs).....	19	Operation Keys.....	9
Discharge time.....	2	Output performance (U, V, W).....	18
<b>E</b>		Overcurrent protection.....	6
Edit Set-up.....	11	Overvoltage Control.....	11
Electronic waste.....	4	<b>P</b>	
<b>G</b>		Power circuit - overview.....	8
Ground leakage current.....	3	Protection.....	6
Ground wire.....	2	Protection and features.....	18
Grounding.....	2	<b>Q</b>	
<b>H</b>		Quick Menu.....	9
Hand mode.....	12	<b>R</b>	
High voltage.....	2	RCD.....	3
<b>I</b>		Relay output.....	20
Isolated line power source.....	3	<b>S</b>	
IT line power.....	3	Slip Compensation.....	11
		Status.....	9
		Surroundings.....	20

**T**

Thermal Protection..... 3

Thermistor..... 11

**U**

UL compliance..... 6

Unintended start..... 2

**V**

Voltage level..... 19

**W**

Warnings and alarms..... 15





[www.danfoss.com/drives](http://www.danfoss.com/drives)

.....  
Danfoss shall not be responsible for any errors in catalogs, brochures or other printed material. Danfoss reserves the right to alter its products at any time without notice, provided that alterations to products already on order shall not require material changes in specifications previously agreed upon by Danfoss and the Purchaser. All trademarks in this material are property of the respective companies. Danfoss and the Danfoss logotype are trademarks of Danfoss A/S. All rights reserved.  
.....

